

AudioControl®

Making Good Sound Great™

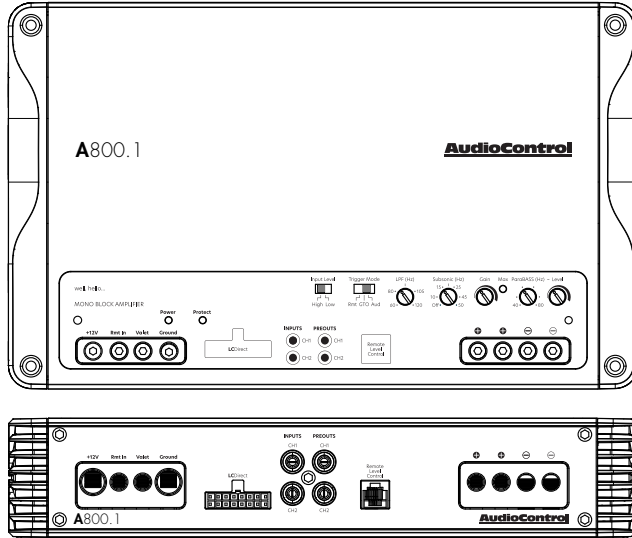

Features

- 1 x 400 W @ 4 Ohms, 1 x 600 W @ 2 Ohms, **1 x 800 W @ 1.33 Ohms**
- High Current Design
- 2 RCA Line Inputs
- 2 RCA Line Outputs
- GTO™ Signal Sense
- Subsonic Filter -24 dB Linkwitz-Riley
- ParaBASS® Low Frequency Contouring
- Independent -12 dB Linkwitz-Riley Crossovers
- Optional wired ACR-1 Remote Control for Subwoofer Level
- Valet Mode Enabled
- LC Direct High Level Input
- Start-stop compliant
- EV compliant up to 17V
- Sleek Chassis Design
- SPIKE MODE enabled

A800.1

Mono-Block Amplifier

Quick Start Guide

Important Safety Instructions

1. Read these instructions.
2. Keep these instructions.
3. Heed all warnings.
4. Follow all instructions.
5. Do not use this apparatus near water.
6. Clean only with a dry cloth.
7. Do not block any ventilation openings. Install in accordance with the vehicle manufacturer's instructions.
8. Do not install near any heat sources such as mufflers, silencers, exhaust pipes, or other apparatus (including amplifiers) that produce heat.
9. **WARNING:** Improper installation may lead to permanent injury or death. Installation of the apparatus must be done with great care by qualified personnel, to prevent damage to fuel lines, power, and other electrical wiring, hydraulic brake lines, and other systems, that might compromise vehicle safety.
10. Provide +12V and Ground insulated wiring of 8 to 4 AWG to ensure adequate current to the amplifier.
11. Use rubber grommets to protect wiring whenever passing wires through metal openings or bulkheads.
12. Only use attachments/accessories specified by the manufacturer.
13. Refer all servicing to qualified service personnel. Servicing is required when the apparatus has been damaged in any way, such as the power input terminals are damaged, liquid has been spilled or objects have fallen into the apparatus, the apparatus has been exposed to rain or moisture, does not operate normally, or has been dropped.

14. This apparatus shall not be exposed to dripping or splashing, and no object filled with liquids, shall be placed on the apparatus.
15. Fuses inside the fuse holder at the battery shall be replaced only with the correct type and fuse value, and only when the apparatus is powered off.
16. Exposure to high sound pressure levels may lead to permanent hearing loss. Take every precaution to protect your hearing.



The lightning flash with arrowhead symbol within an equilateral triangle is intended to alert the user to the presence of uninsulated "dangerous voltage" within the product's enclosure, that may be of sufficient magnitude to constitute a risk of electric shock to persons.



The exclamation point within an equilateral triangle is intended to alert the user of the presence of important operating and maintenance (servicing) instructions in the literature accompanying the appliance.

Caution: to reduce the risk of electric shock, do not disassemble the apparatus, other than to remove the top panel to access the controls. There are no user-serviceable parts inside. Refer servicing to qualified personnel.



Recycling notice: If the time comes and this apparatus has fulfilled its destiny, do not throw it out into the trash. It has to be carefully recycled for the good of mankind, by a facility specially equipped for the safe recycling of electronic apparatus. Please contact your local or state recycling leaders for assistance in locating a suitable nearby recycling facility. Or, contact us and we might be able to repair it for you.

Connection Panel Features

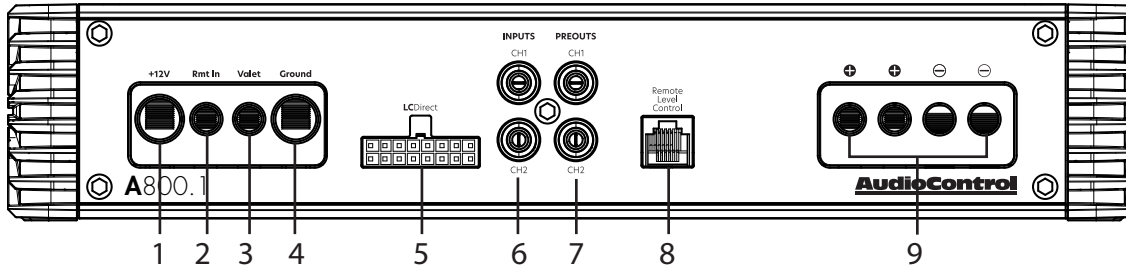

- 1. Power Input Terminal +12V** – This screw terminal connects to the +12V battery binding post of the vehicle. Use quality insulated wire, 4 AWG.
- 2. Remote Power Input Terminal** – This screw terminal connects to the 12V remote trigger output of some head units. When the head unit is turned on, then the A800.1 will turn on.
- 3. Valet Mode Connection** - This screw terminal connects to an optional switch to lower the max volume to 25% when switched on.
- 4. Power Input Terminal Ground** – This screw terminal connects to a good ground connection on the vehicle. Use quality insulated wire, gauge 4 AWG.
- 5. LC Direct** – The speaker-level output (20V MAX) from amplifiers and factory installed radios can connect here. Do not use these inputs if you are using the RCA line-level inputs.
- 6. RCA Analog Line-Level Inputs** – The line-level output from an aftermarket head unit can connect here. Do not use these inputs if you are using the speaker-level inputs (LC Direct).
- 7. RCA Analog Line-Level Outputs** – The line-level output can supply signal to additional amplifiers as needed.
- 8. Remote Level Control (optional)** – This port connects to the ACR-1 remote level control.
- 9. Speaker-Level Output Terminals** – These screw terminals connect with speaker wire to the subwoofer, or multiple subwoofers. Make sure that the speaker impedance does not dip below 2 Ohms or see page 13 for SPIKE MODE use.

Top Cover Removal

The top cover must be removed to gain access to the controls, and then put back on again to protect the controls from dust bunnies.

Removal Procedure

1. Locate the two screws holding the top cover on the amplifier.
2. Use the supplied hex key to loosen both screws just enough until the edge of the cover can lift freely up just a little. (There is no need to remove the screws all the way, in case you lose them.)
3. Lift the cover off of the amplifier.
4. Place the cover in a safe and handy place, ready for the time when you have finished adjusting the controls to your immense satisfaction, and just before Alfred brings tea and sandwiches.

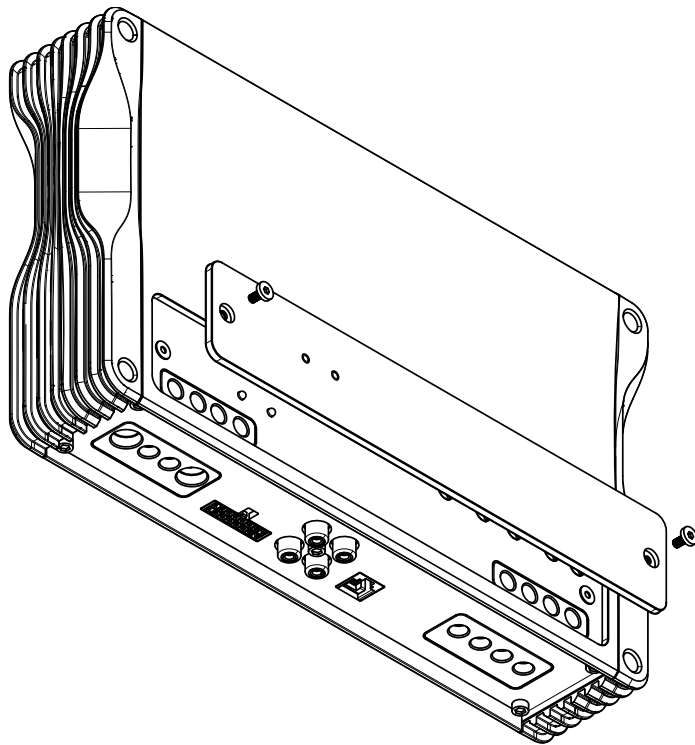

A800.1

Control Panel Features

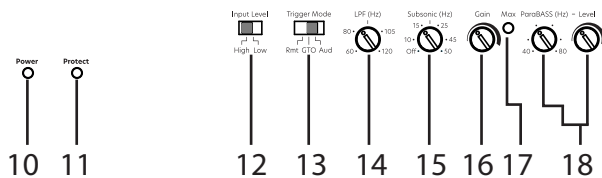
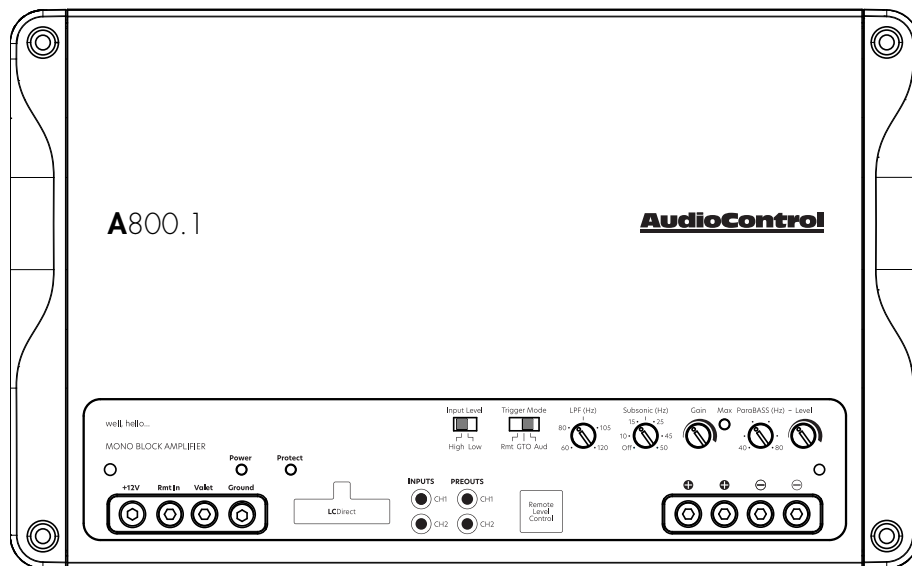

-
- 10. Power LED** - If you have connected your battery power, vehicle ground, and turn-on lead (or used an alternative signal sensing turn on mode correctly), then this light should be illuminated white to indicate the amplifier is powered ON.
- 11. Protection LED** – If this LED illuminates red, this signifies the amp is in protection mode and something is wrong. If cycling the power to the amplifier does not take amp out of protection then disconnect speaker wires and cycle power. If the amp is no longer in protection then check speaker and wires for shorting. If light stays on with speaker wires disconnected then contact AudioControl Technical support for further instruction. If the LED illuminates amber, this signifies the amp is in Valet Mode.
- 12. Input Level Switch** – High (LC Direct) = 1.5-20 volts, Low (RCA) = 0.5 -6 volts. Select High for most systems using a factory stereo as the source. Select Low for most systems using an aftermarket source unit, LOC, or DSP.
- 13. Remote / GTO / Audio** – (Rmt) Select this mode when the remote turn-on signal from an aftermarket head-unit, LOC, or DSP is present to turn the amp ON. (GTO™) *for Ch 1 High Level Input Only*: Choose this mode when no turn on signal is available, and the amplifier will gracefully turn on when it detects your source unit powering up, then turn off after the source unit powers down, (Aud) When this mode is selected, the amplifier will turn ON when it detects audio signal from Ch 1 is present on the inputs, regardless of the source. If you turn the head unit on, but

DON'T play audio, the amplifier will not turn on when using this turn on mode.

- 14. Low Pass Crossover** – A crossover allows you to match a speaker to the frequency range it is designed to handle. Choosing the crossover point recommended by the speaker manufacturer will provide increased speaker reliability and optimum sound quality. The A800.1 amplifier has selectable low pass crossover frequencies at 60 Hz-120 Hz. The amplifier produces the frequency range below the selected crossover frequency.
- 15. Subsonic Filter** – The Subsonic filter is normally used on a vented subwoofer enclosure. Recommended setting is 1/2 octave below the enclosure tuning frequency.
- 16. Gain** – Use this dial to match the source unit's output voltage with the inputs of amplifier channels 1 & 2. Remember, this is NOT a volume knob.
- 17. Max. Indicator** – This LED indicates when channels 1&2 have been optimized for maximum performance. This LED should illuminate momentarily during brief bursts of music playback at max volume. In most scenarios, it should not be constantly illuminated for long periods of time.
- 18. ParaBASS®** Two simple controls allow for killer bass tweaking. The ParaBASS (Hz) knob selects the center frequency, between 40 Hz and 80 Hz. The level knob provides up to 10 dB of boost centered around the ParaBASS® frequency.

ACR-1 (Optional)

ACR-1 remote

The optional AudioControl ACR-1 dash control is a remote level control for your A800.1 amplifier. It may be mounted under the dash using its own enclosure, or through a custom hole in the dash. The level control knob should be within reach of the driver, and in a spot where the LED is plainly visible. Insure the amplifier is powered off when connecting the ACR-1.

Dash Bracket Installation: The dash control mounts with two screws, which attach to the underside of the dashboard. Slide under the dash and place the dash control in its mounting position, mark the two best mounting holes, drill pilot holes, and secure with two screws.

Custom Installation: For that custom, finished look, the dash control can be flush-mounted directly on the dashboard (or anywhere else). See ACR-1 manual/packaging for details and diagram.

The long-awaited moment when “plethora” is used in a manual

The plethora of A800.1 controls allows for a wide variety of installation possibilities. This quick start guide gives a few examples of system diagrams reference (pages 11-13) and includes a few notes about the control settings for each one.

Note: The technical writer reserves the right to be wrong about things, due to the cold medicine being the night-time sleepy stuff, and not the usual day-time strength.

We left this page for you to marvel in the pure white.
Move to next page once you have had enough.

Quick Start

Here are a few general steps to get your A800.1 amplifier up and running:

1. Undo the +12V and Ground connections to the car battery before making any connections to the amplifier.
2. Pick a mounting location that will provide access to the controls and connections, provide adequate ventilation, and also protect the amplifier from heat, moisture, and dirt. Make sure that the heat-sink fins are not covered.
3. The A800.1 amplifier needs to be securely mounted using the four mounting holes located in each corner.
4. Before drilling any holes, take every precaution to prevent any damage to fuel lines, power and other electrical wiring, hydraulic brake lines, and other systems, that might compromise vehicle safety.

5. When making connections, designate red RCA plugs as right, and designate white, black, or grey plugs as left. This is a good idea for consistency.
6. Use quality interconnect cables.
7. Always connect the amps Ground terminal first before connecting the 12V power wire to the amp. Not following these instructions could result in damaging the amp and this would not be covered under warranty. Also **NEVER REMOVE THE GROUND WIRE from the amp while the 12V wire is connected.**
8. Connect the Ground terminal of the unit to the chassis of the vehicle, using 4 AWG wire. Connect the +12V wire using the same gauge wire as the ground wire.
9. Connect the remote power terminal of the amp to the remote turn-on output of your source unit. Alternatively, you can skip this connection and use the GTO / Aud turn-on method.
10. Connect your audio inputs to the amp – either speaker-level or line-level RCA... not both.
11. Run the optional ACR-1 remote to the front of the vehicle to adjust the output level on the fly.
12. Connect your loudspeakers (2ohm suggested or 1.33 ohms for SPIKE MODE).
13. Once all connections are made, reconnect the vehicle battery.
14. Adjust your input source gain using the MAX Clip LED. When the Audio is playing look at the light and when the music peaks the light should flash.
15. Set the A800.1 crossovers to the frequency recommended by the loudspeaker manufacturer.
16. Adjust the Subsonic filter when using a vented enclosure.
17. Enjoy the drive!

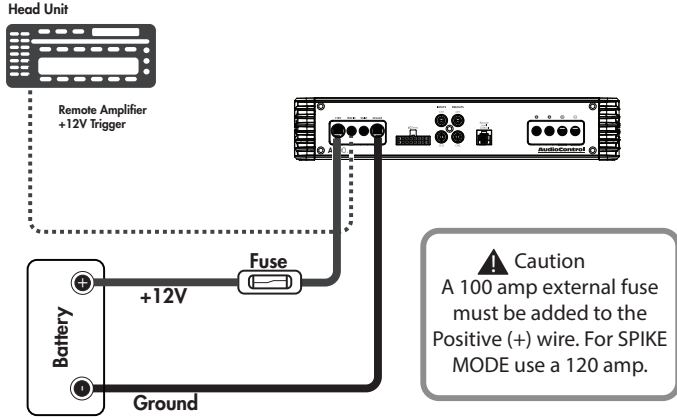
Power Connections

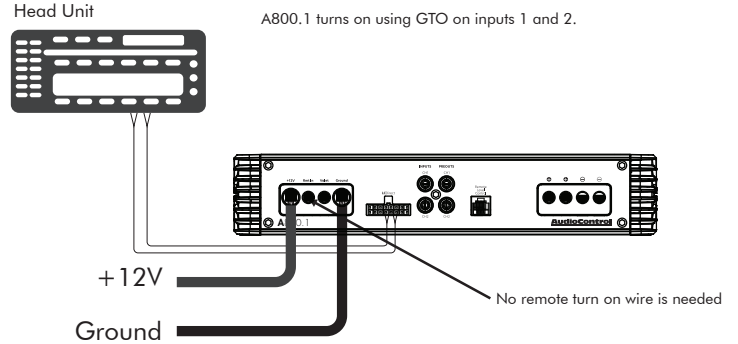

In this example, the head unit has a +12V trigger output that is connected to the A800.1 remote input terminal. When the head unit is turned on, it will turn on the A800.1 amplifier.

Use 4 AWG insulated wire for the +12V and Ground connections.



In this example, the GTO signal sense feature can be used to gently turn on the A800.1 amplifier when an audio input signal is detected on inputs 1.

System #1: Adding a Subwoofer to a Factory Radio using Speaker-Level Inputs

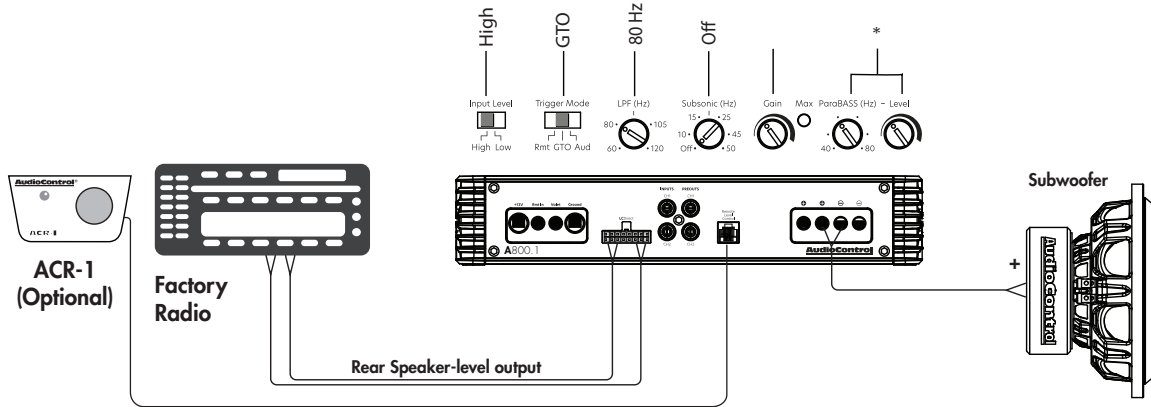

Notes:

The +12V Power and Ground connections are not shown

- **Input Level:** Input level is set to High.
- **Trigger mode:** Set the trigger mode to GTO.
- **LPF (Hz):** Set the LP filter to 80 Hz.
- **Subsonic (Hz):** Set the Subsonic to Off.
- **Gain:** Set desired Gain level.
- **ParaBASS® (*):** If you notice a deficiency in your bass response output, you can use the ParaBASS® feature to dial into a specific frequency and boost the response back to your liking.

System #2: Adding a Subwoofer to an Aftermarket Radio using Line-Level Inputs

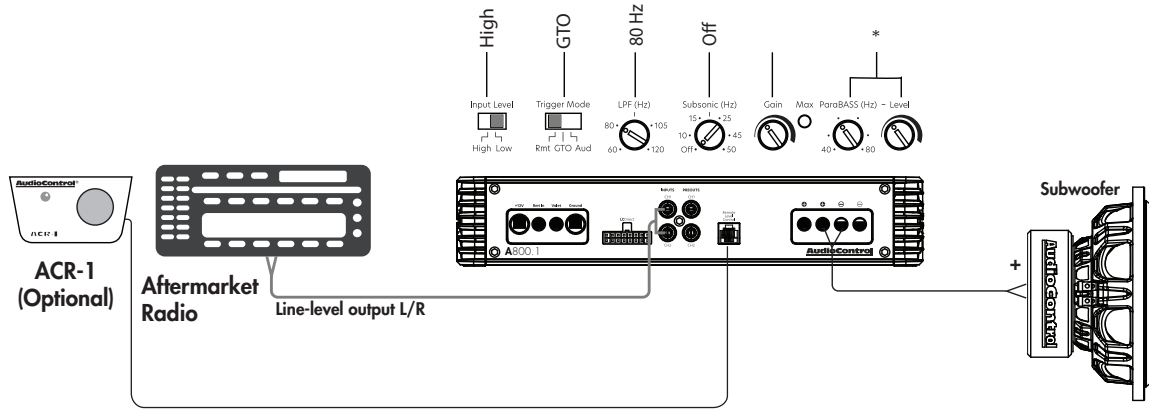

Notes:

The +12V Power and Ground connections are not shown

- Input Level: Input level is set to Low.
- Trigger mode: Set the trigger mode to Rmt.
- LPF (Hz): Set the LP filter to 80 Hz.
- Subsonic (Hz): Set the Subsonic to Off for sealed enclosures and On for vented.
- ParaBASS® (*): If you notice a deficiency in your bass response output, you can use the ParaBASS® feature to dial into a specific frequency and boost the response back to your liking.

System #3: SPIKE MODE!

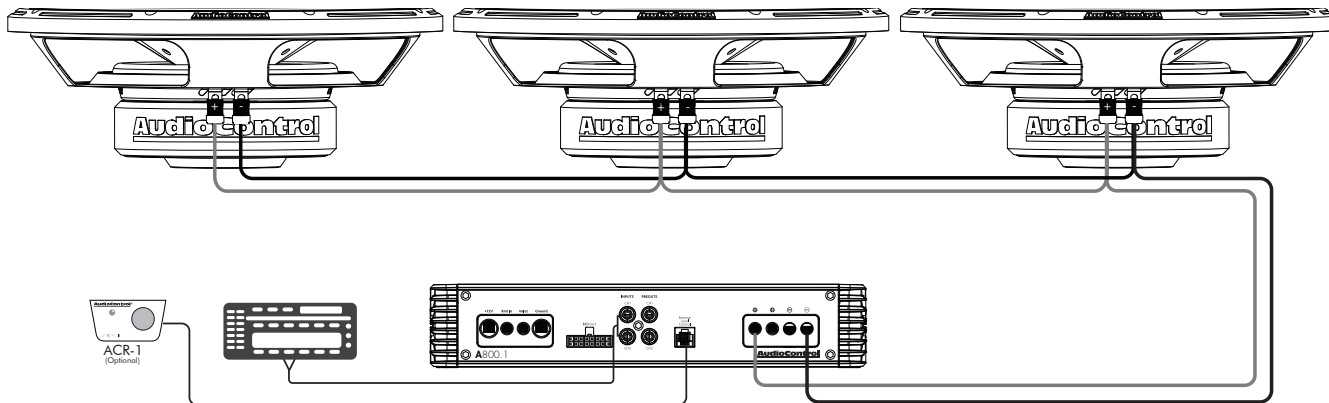

Notes:

Aftermarket Radio connected.

The +12V Power and Ground need a 4 AWG wire for SPIKE MODE.

For a 3 subwoofer configuration we recommend using a 12 AWG speaker wire.

Speaker outputs connects to 3 x 4 ohm single voice coil subwoofers, this gives you 1.3 ohms.

Each subwoofers positive terminal is connected in parallel to each subwoofer.

Each subwoofer negative terminal is connected in parallel to each subwoofer.

- Input level is set to Low.
- Trigger mode is set to Rmt.
- LP filter is adjusted to 80 Hz.
- Subsonic filter is set to Off with sealed enclosure.
- Subsonic filter set to half octave below the tuning frequency with vented enclosure.
- Set Gain level right below Max clipping light.
- ParaBASS® (*): If you notice a deficiency in your bass response output, you can use the ParaBASS® feature to dial into a specific frequency and boost the response back to your liking.



Valet Mode Connection

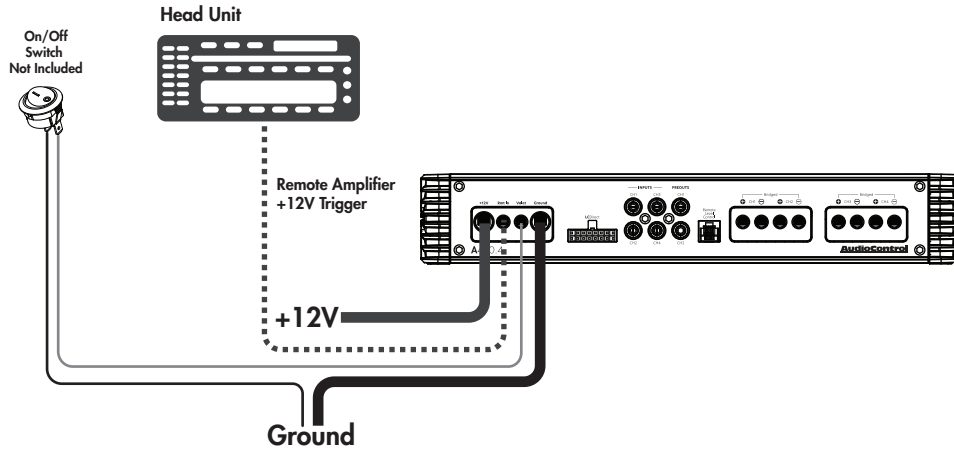

Notes:

- Connect a wire to the Valet terminal on the amplifier.
- Connect the other end to a On/Off switch. (Any 2 prong On/Off switch should work)
- Connect the other open switch prong to chassis ground.

When the Valet switch is activated, the amplifier limits maximum volume to 25%, protecting your audio system from the wiles of the wayward but well-meaning valet.

Specifications

All specifications are measured at 14.4 VDC (standard automotive voltage). As technology advances, AudioControl reserves the right to continuously change our specifications, like our Pacific Northwest weather, although we are working on a surround-sound umbrella as well.

A800.1 Mono Block Amplifier

Power Output.....	1 x 400 Watts @ 4 Ω
.....	1 x 600 Watts @ 2 Ω
.....	1 x 800 Watts @ 1.33 Ω
S/N Ratio	-110.2dBa dBa, Ref 400 Watts @ 4 Ω
THD+N	<0.14%
Power / Ground Wire Gauge.....	4 AWG
Crossover.....	-12 dB/Octave Linkwitz-Riley, Adjustable From 60 Hz to 120 Hz
Subsonic	-24 dB/Octave Linkwitz-Riley, Adjustable From 0 Hz to 50 Hz
Speaker-Level Inputs.....	20 V max
Line-Level Inputs.....	6 V max
Recommended Fuse rating.....	100A
Weight	6.05 lbs
Dimensions.....	10.9"W x 6.7"D x 2.1"H

©2024 AudioControl. All rights reserved.

For more information about this fine product, and for details of the limited warranty, and repair services, please visit our website at

www.audiocontrol.com

All specifications are subject to being covered in honey without notice.

AudioControl

For more information about this fine product, and for technical questions, additional details of the limited warranty and repair services, please visit www.audiocontrol.com

AudioControl – “a Stinger Company”

15500 Lightwave Drive Suite 202

Clearwater, FL 33760

Mobile audio support:

Phone: 425-777-7723

Email: support@audiocontrolmobile.com

As Technology advances, AudioControl reserves the right to continuously change our specifications.

© 2024 Stinger. All rights reserved. AudioControl is a Stinger Company.

AudioControl®

Making Good Sound Great™

The Warranty

In just the same way as walking into a room and seeing a big hairy spider on the wall, people are scared of warranties. Lots of fine print. Months of waiting around. Well, fear no more. This warranty is designed to make you rave about AudioControl. It's a warranty that looks out for you and your client, plus helps you resist the temptation to have your friend Sparky, who's "good with electronics," try to repair your AudioControl product. So go ahead, read this warranty, then register the information at www.audiocontrol.com/product-registration and include your comments.

Our warranty has conditional conditions! "Conditional" doesn't mean anything ominous. The Federal Trade Commission tells all manufacturers to use the term to indicate that certain conditions have to be met before they'll honor the warranty. If you meet all of these conditions, AudioControl will, at its discretion, repair or replace any AudioControl Altitude products that exhibit defects in materials and/or workmanship for one (1) year from the original date you bought it. We will repair or replace it, at our option, during that time.

Here are the conditional conditions:

1. You must fully register your purchase within 15 days of the purchase date by going to the AudioControl product registration page at:
www.audiocontrol.com/product-registration
Failure to register your product will negate the warranty.
2. You need to hold on to your sales receipt! All warranty service requires original sales receipt documentation. The warranty only applies to the original purchaser from an authorized AudioControl dealer. Note: Products purchased from unauthorized dealers are not covered under warranty.

3. The AudioControl Altitude products must have originally been purchased from an authorized AudioControl dealer. **If an authorized AudioControl dealer installs your AudioControl product, they also must use all Stinger power management and the warranty is extended to (3) years.**
4. Our warranty covers AudioControl products that have been installed according to the instructions in this manual.
5. You cannot let anyone who isn't: (A) the AudioControl factory; or (B) someone authorized in writing by AudioControl, service your AudioControl product. If anyone other than (A), or (B) messes with your AudioControl product, the warranty is void.
6. The warranty is void if the serial number is altered, defaced or removed, or if your product has been used improperly. Now that may sound like a big loophole, but here is what we mean by this: Unwarranted abuse is: (A) physical damage (don't use your product to pound in fence posts); (B) improper connections (120 volts into the amplifier terminals can fry the poor thing). This is the best product we know how to build, but for example, if you mount it to the front bumper of your car, drop it over Niagara Falls, or use it for anchoring your boat, something will go wrong.

Assuming you conform to 1 through 6, and it really isn't all that hard to do, we get the option of fixing your product, or replacing it with a new one, at our discretion.

In the event that your product is out of warranty or not covered under our warranty, you may request to have any damage repaired at our normal "Out of Warranty" repair cost.